

6.00

SYSTEM CONNECTIONS

Hunter Underground Systems

6.01 System Connections

6.01

SYSTEM CONNECTIONS

CONNECTIONS TO OTHER MATERIALS

Hunter has various types of connector for connecting to other drainage materials. See the following installation diagrams for more details. When connecting to an existing drain, the age of the property may indicate the type of drain materials used, alternatively, expose the drain to determine if it is made of PVCu, clay or another material. Unlike the old drainage methods, all modern drainpipes must have flexible joints to accommodate ground movement without fracturing the pipe.

Cast Iron Drainpipe

The connectors DS349 or DS438 are designed to be placed into the cast iron drain socket and caulked in position with yarn and lead, as shown in the diagram, leaving a push fit socket for the PVCu pipe.

There are several types of clay pipe.

Glazed Vitrified Clay (GVC) or Salt Glazed Ware. The oldest form of clay pipe was still being used around the late 1960's early 1970's. It has a glazed surface and was jointed by rigid sockets filled with cement mortar. The connectors DS349 or DS438 are designed to be placed into the GVC socket and held in position with yarn and cement mortar, as shown in the diagram, leaving a push fit socket for the PVCu pipe. Alternatively cut the pipe with an angle grinder and use the DS553, which is fitted over the GVC pipe end and is held in position with a yarn and cement mortar joint. (see the diagram) This leaves a 110mm PVCu spigot which is connected to with a push fit socket. Another method is to cut a chamfered end onto the GVC pipe, then you can convert to plastic by using the "Eazisleeve" connector.

The "Eazisleeve" connector is fitted with two stainless steel clamping bands, which are tightened around the pipe ends with a screwdriver or 8mm nutdriver or ratchet spanner. The "Eazisleeve" black rubber flexible connector DS26 will allow 110mm PVCu drain pipe to be joined to a variety of DN100 pipes which have an outside diameter of between 121mm - 136mm. Such as glazed vitrified clay, thick and thin walled vitrified clay, ductile iron or cast iron. The 6" "Eazisleeve" drain connector (DS27) will allow 160mm PVCu drain pipe to be joined to a variety of DN150 pipes which have an outside diameter of between 170-192 mm suitable for glazed vitrified clay, also modern thick and thin walled vitrified clay.

There are two types of modern flexibly jointed Vitrified clay drainpipe to either BSEN 295 or BS65: 1991.

- 1) Thick Walled Vitrified Clay is recognised by its smooth brown matt finish the outside diameter (O.D) of DN100 is approximately 128-130mm while the O.D of DN150 is approximately 188-190mm. The Hunter coupling DS350 is made to push over the 100mm chamfered clay pipe end after chamfering and lubricating both the PVCu and clay pipe ends. The coupler DS347 allows connection of Hunter inspection chambers to DN100 Thick Walled Pipe.
- 2) Thin Walled Vitrified Clay Pipe has been made since about 1984 and is recognised by its smooth dark brown matt finish and black polypropylene couplings. DN100 pipe has an O.D of approximately 120-121mm. The O.D of DN150 is approximately 178-179mm. Hunter's connector DS354 is designed to push into a 150mm (6") black polypropylene Vitrified Clay Pipe coupling. For the smaller 110mm pipe the Hunter coupling DS351 is made to push over the DN100 chamfered Vitrified Clay pipe end, whilst the coupler DS348 allows connection of Hunter inspection chambers to Thin Walled Vitrified Clay Pipe.

6.01

SYSTEM CONNECTIONS

INSTALLATION

Before assembly, always ensure that any Push-fits are wiped clean and the seal housing is free from dirt. Apply lubricant to the clay or PVCu pipe before inserting into the socket. The PVCu pipe should have a 10mm gap for expansion.

CONNECTION TO CLAY SOCKET

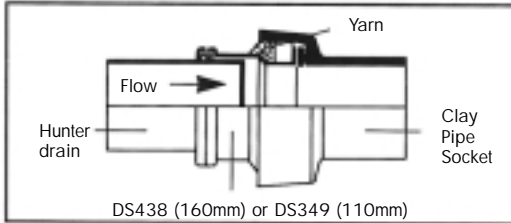

Place adaptor DS349 or DS438 in the cast iron or clayware socket caulked with gaskin yarn, and apply cement mortar in the conventional manner.

CONNECTION TO CAST IRON SOCKET

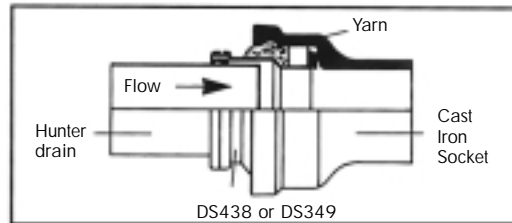

When using the adaptor with a cast iron socket, molten lead or lead wool can be used instead of the cement mortar.

CONNECTION TO THIN WALL CLAY SPIGOT

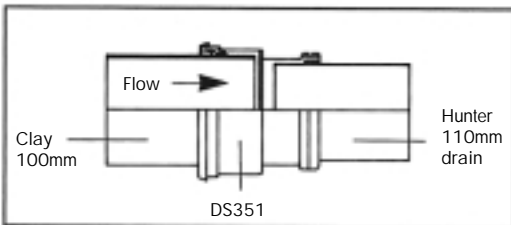

CONNECTION TO THICK WALL CLAY SPIGOT

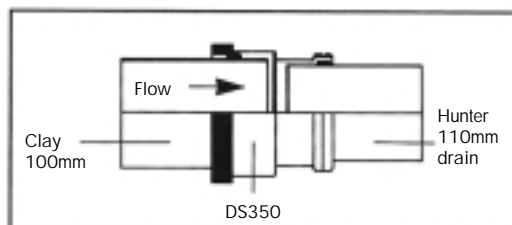

CONNECTION TO THIN WALL CLAY PIPE COUPLING

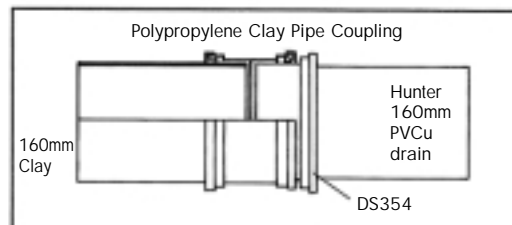

CONNECTING OTHER MATERIALS TO HUNTER INSPECTION CHAMBERS OR HUNTER DRAIN FITTINGS

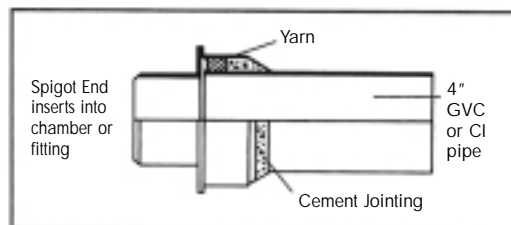

Connection is made using the DS553 adaptor which has the internal socket surfaces treated to obtain a key. Spigot of clayware or cast iron is inserted into the adaptor socket. Firmly caulk with three turns at tarred gaskin and using cement mortar final joint in normal manner

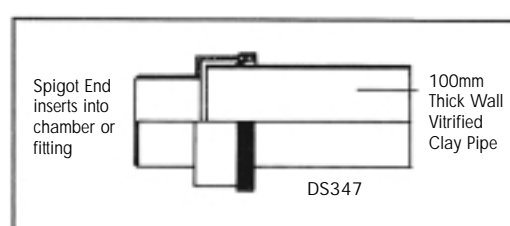
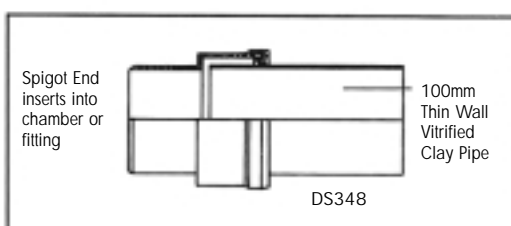

6.01

SYSTEM CONNECTIONS

CONNECTION TO HUNTER INSPECTION CHAMBER

DS347 ADAPTOR
110mm PVCu to Thick Wall Clay

DS348 ADAPTOR
110mm PVCu to Thin Wall Clay

DS347 or DS348 lubricated and pushed into chamber socket

Clayware spigot, chamfered, lubricated and pushed into adaptor socket

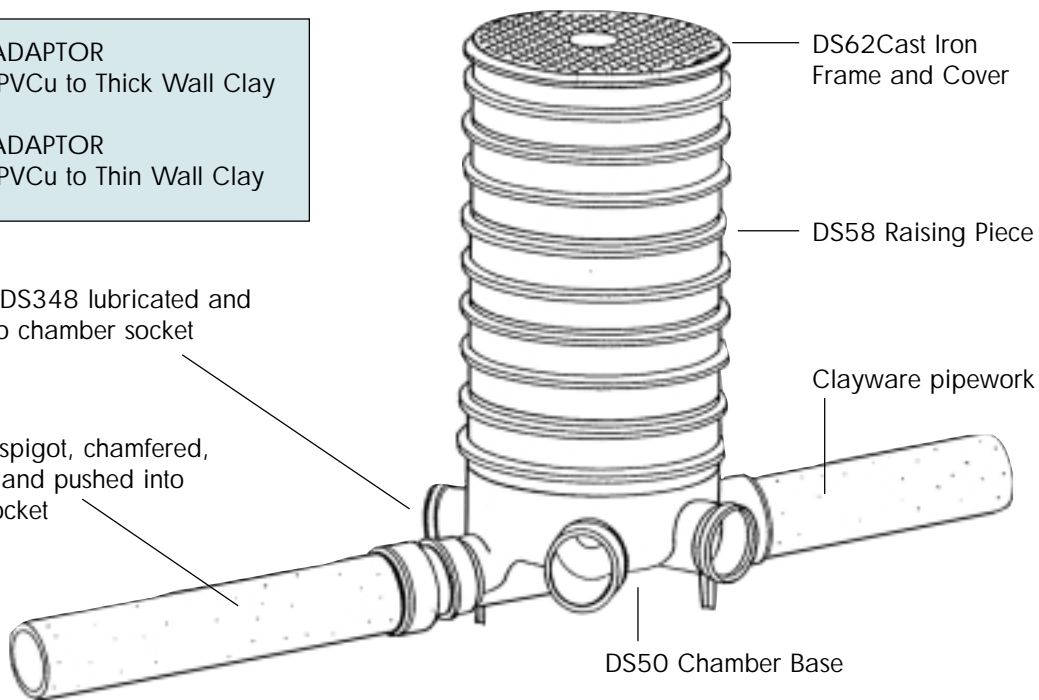

CONNECTION TO HUNTER SHALLOW ACCESS CHAMBER

HUNTER INSPECTION CHAMBER
CLAYWARE ADAPTORS

DS69 PVCu Cover and Frame

DS39 Aluminium Cover and Frame

DS72 Raising Piece

Clayware pipework

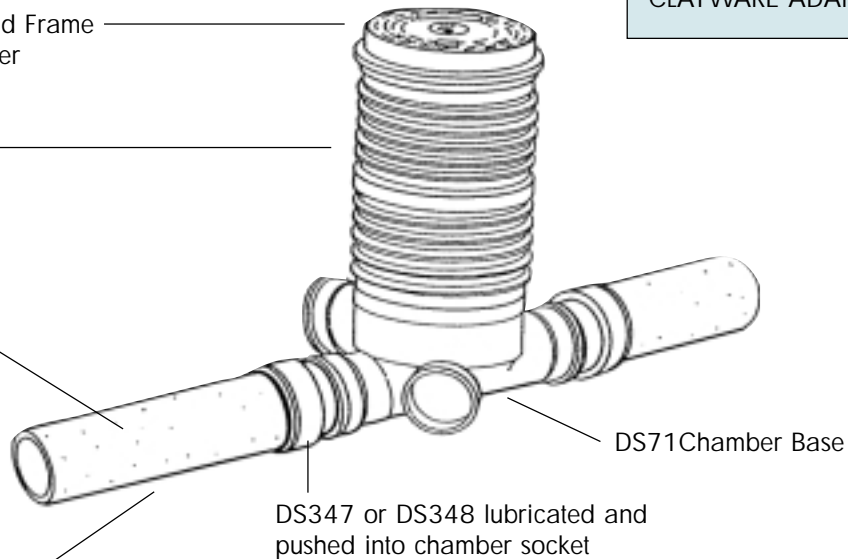

Clayware spigot, chamfered, lubricated and pushed into adaptor socket

Clayware adaptors may be used in any of the chambers inlets/outlets

6.01

SYSTEM CONNECTIONS

HUNTER DRAIN CONNECTORS

DS350 110MM PVCu TO THICKWALL CLAY

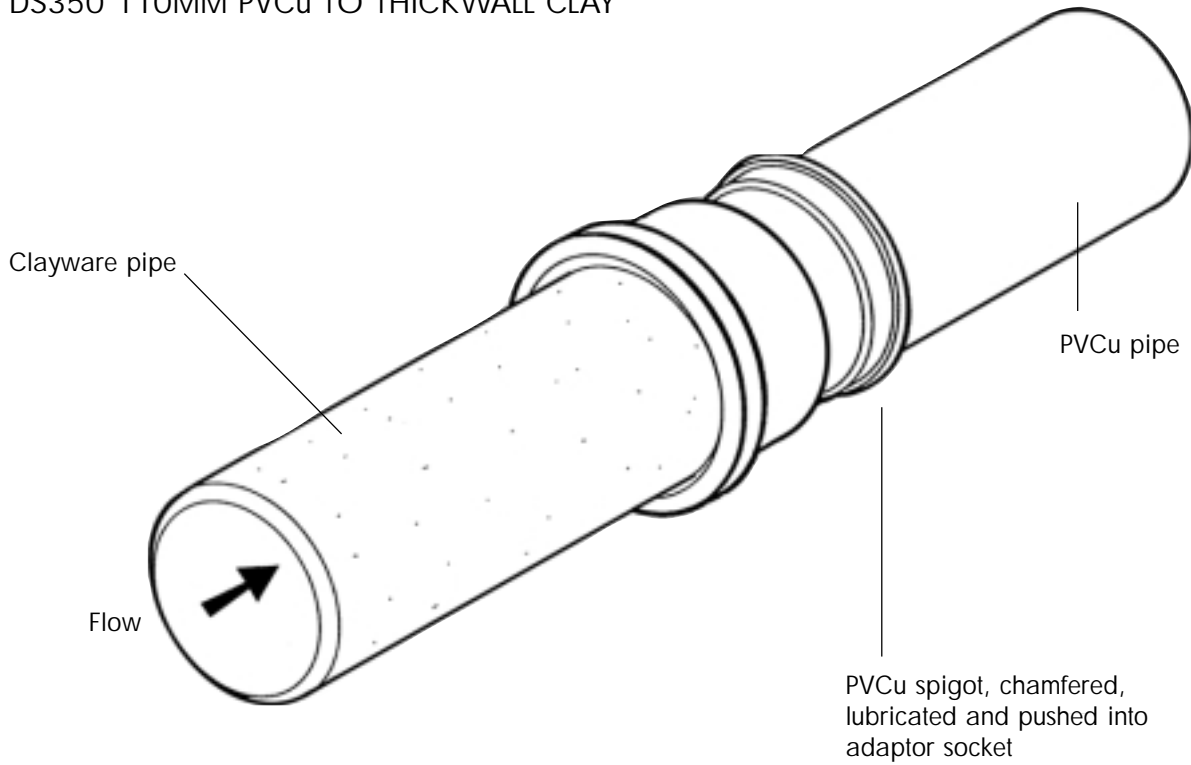

CONNECTION TO HUNTER SHALLOW ACCESS CHAMBER

DS351 110MM TO THINWALL CLAY

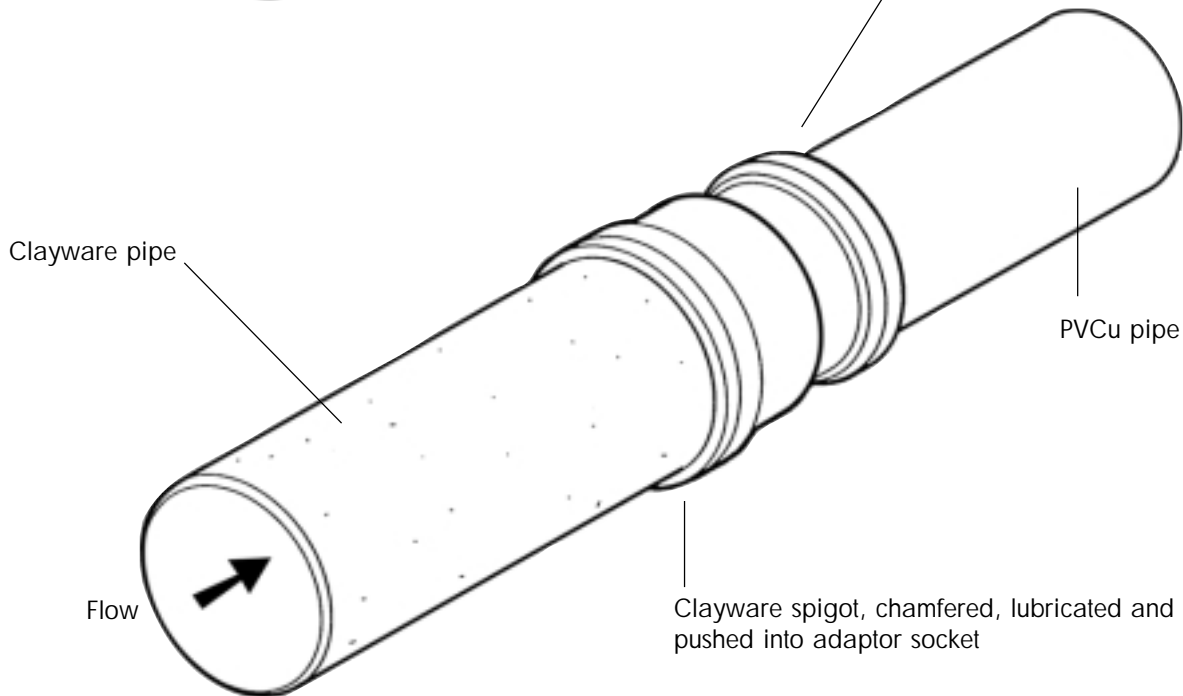

6.01

SYSTEM CONNECTIONS

CONNECTION TO EXISTING PVCu |

Mark a section of pipe to be cut over 500 mm long.

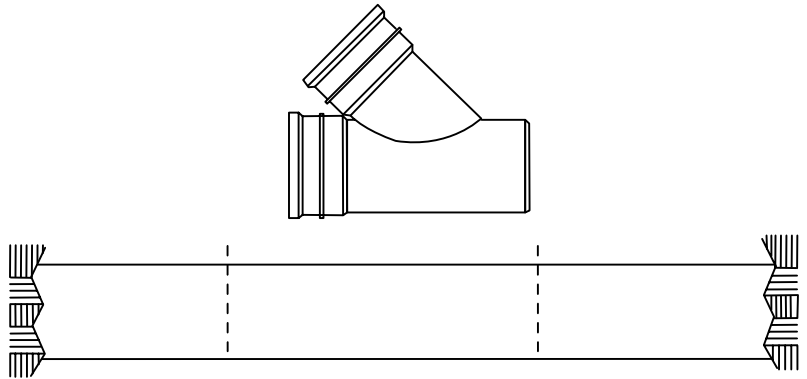

Cut with a fine-toothed saw and chamfer both ends.



Lubricate the pipe ends and slide on the slip couplings (DS212 or DS410).



Cut one short length of pipe from cut piece. Chamfer, lubricate and insert into the branch socket.

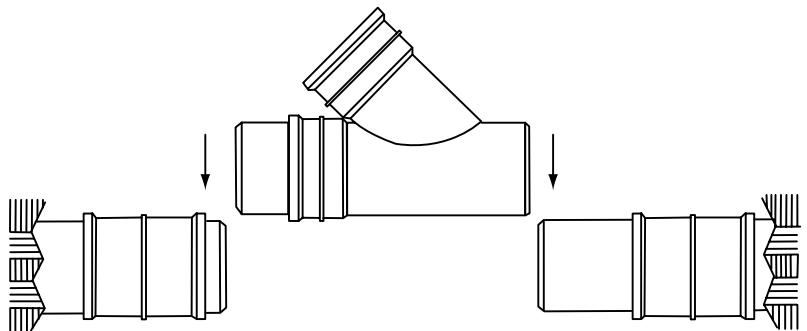

Lubricate the pipe ends and drop into position leaving expansion gaps at both ends.

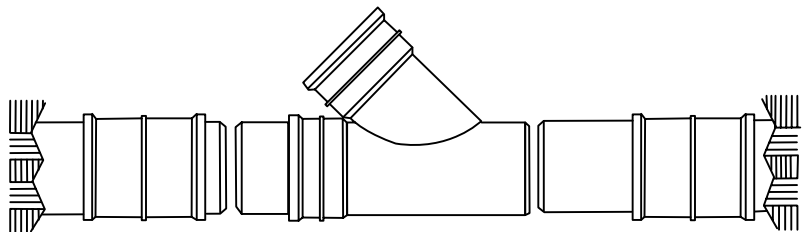

Slide the slip couplings over the pipe spigots and test the installation.

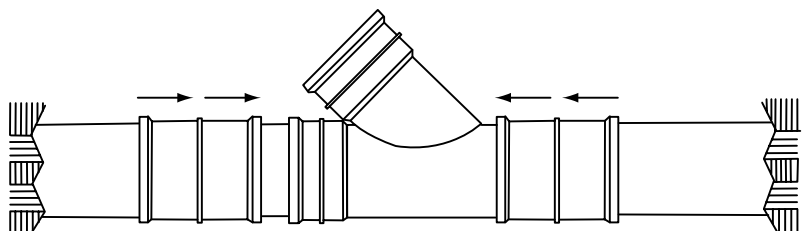

6.01

SYSTEM CONNECTIONS

BOSS CONNECTIONS

Back inlet bosses are found on the Bottle Gullies DS46 and DS49, also on the short boss pipe DS30 and on the access pipe DS309 and DS472. To prevent the internal bore of the closed bosses being damaged, a 48mm hole cutter must be used when drilling out the closed bosses. Remove the swarf before fitting the boss adaptor.

Connectors 1 and 2.

The boss adaptor rubbers (W58 and W59) can be used for connecting both polypropylene pipes (BS EN1451), (MUPVC) modified unplasticized polyvinyl chloride pipe (BS5255) and copper waste where an expansion connection is acceptable. The boss rubbers will push inside the bosses. The W59 will reduce the opening to connect 40mm pipe and the W58 is used to connect the 32mm pipe.

Connectors 3 and 4.

If a solvent weld connection is required for pipe, the W106 and W104 reducers will be used. The W106 will connect 40mm pipe and the W104 will reduce the opening to connect the 32mm pipe.

Connectors 5 and 6.

A straight solvent adaptor (S750) will solvent over the outside of the boss to connect 50mm solvent pipe, and the push fit adaptor (S751) will push over the bosses for 50mm push-fit pipes.

Connectors 7 and 8.

The angled solvent weld adaptors will solvent over the outside of the boss to connect 50mm solvent pipe. These are the S753 50mm angled (2½°) solvent weld adaptor and the W725 50mm angled (90°) solvent weld adaptor.

Example of Boss Connections

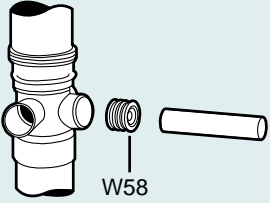
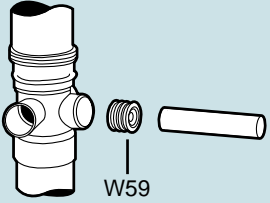
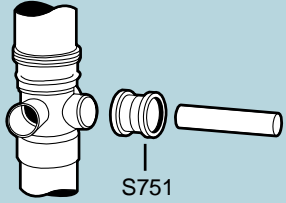
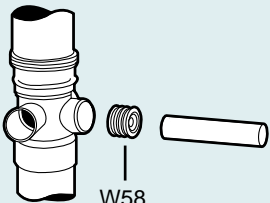
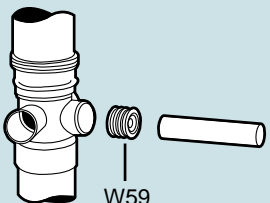
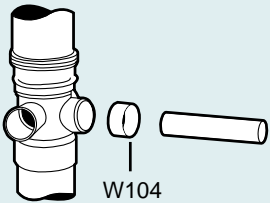
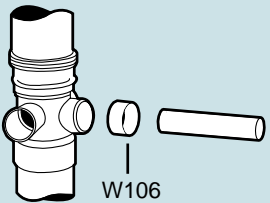
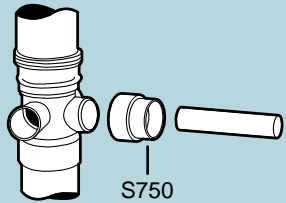
HUNTERS 'EASY TO USE' BOSS CONNECTIONS		
32mm	40mm	50mm
CREATES PUSH-FIT CONNECTION – PUSH-FIT PIPEWORK TO BSEN1451		
		
CREATES PUSH-FIT CONNECTION – SOLVENT WELD PIPEWORK TO BS5255		
		
CREATES SOLVENT WELD CONNECTION – SOLVENT WELD PIPEWORK TO BS5255		
		
ANGLED OPTIONS FOR SOLVENT WELD PIPEWORK		
2.5°		S753
90°	W104 + W111	W725

6.01

SYSTEM CONNECTIONS

RAINWATER PIPE TO BOTTLE GULLY BACK ENTRY

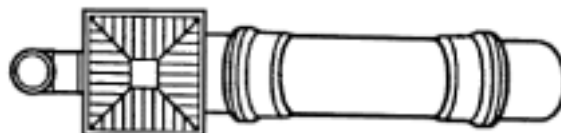
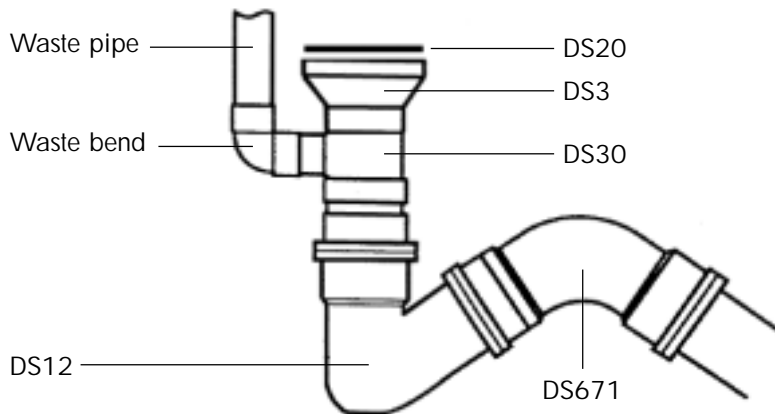
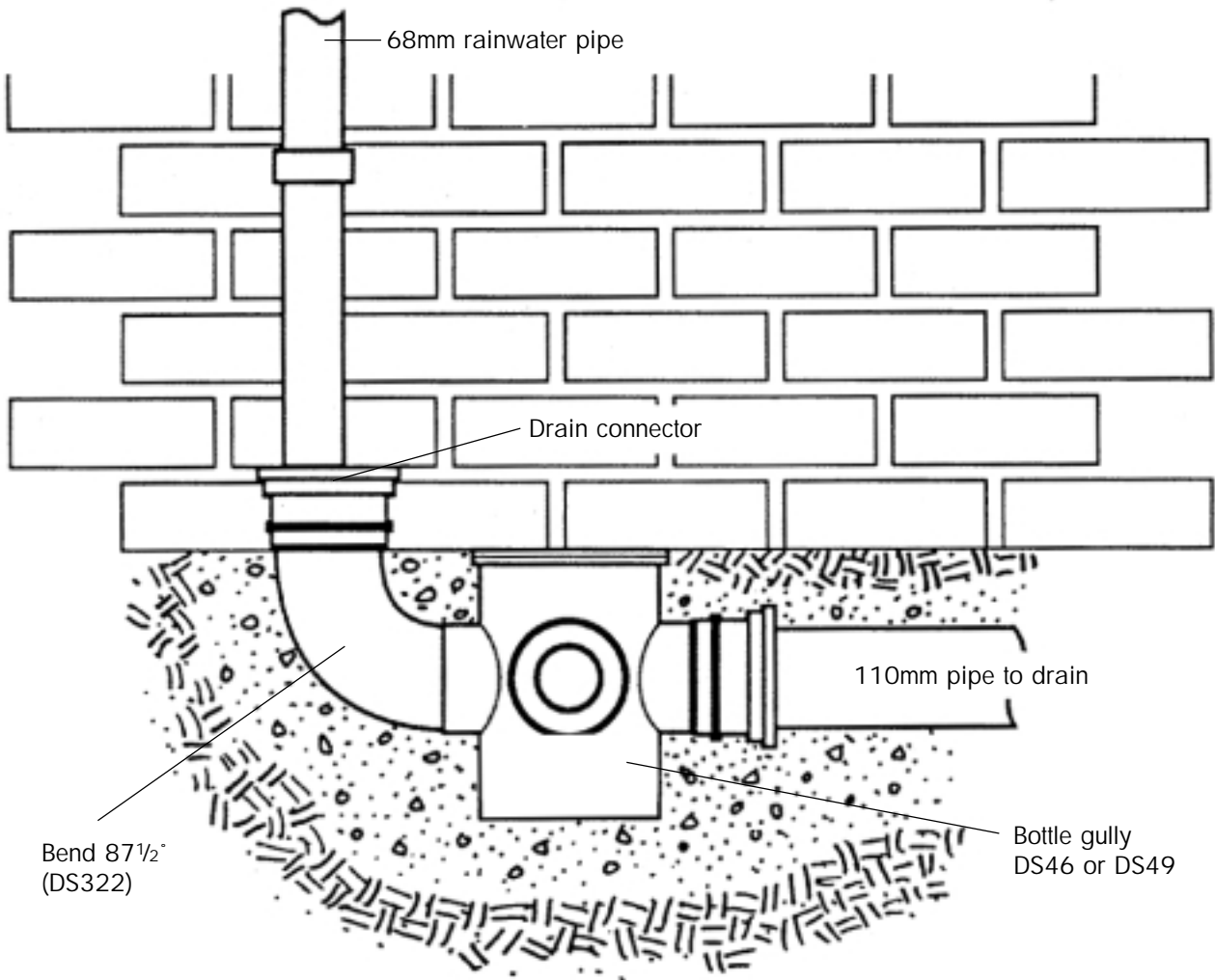

PLAN